

DLT2-60

Telescopic articulated, material handling or personnel

DUR-A-LIFT®



DLT2-60DU PICTURED

SPECIFICATIONS

DLT2-60

WORKING HEIGHT*	67'
SIDE REACH	39'2"
APPROX. STOWED TRAVEL HEIGHT	12'
HEIGHT TO BOTTOM OF PLATFORM*	62'
BASKET CAPACITY (MH, DU)	400#
BASKET CAPACITY NOT USING JIB (DU)	550#
BASKET CAPACITY (DP)	600#
APPROX. LIFT WEIGHT	5950#
ARTICULATING ARM TRAVEL	0° to 91°
MAIN BOOM TRAVEL	-26° to 75°
EXTENSION TRAVEL	134"

- WORKING HEIGHT UP TO 67'; SIDE REACH TO 39'2"
- MATERIAL HANDLING OR DOUBLE-PERSON
- 180-DEGREE BASKET ROTATOR
- BASKET ELEVATOR OPTION
- TOP-MOUNTED JIB LIFTS UP TO 1000#
- INSULATED (DLT2); NON-INSULATED (DLT2S)

TOP-MOUNTED JIB & WINCH

The optional top-mounted jib and winch (DU, MH baskets) allows the operator to rotate the jib to work on either side of the rotating basket.



DUR-A-LIFT®

WE SPEAK BUCKET TRUCK

Dur-A-Lift Inc. reserves the right to improve models and change specifications without notice or obligation. Dur-A-Lift equipment meets or exceeds all applicable ANSI Standards as of the date of manufacture.
*Maximum height achievable with addition of the optional 22" basket elevator.

DLT2-60

Telescopic articulated, material handling or personnel

DUR-A-LIFT
WE SPEAK BUCKET TRUCK

STANDARD

Proportional controls; lower override controls; engine start/stop from basket; basket access from ground; compensated upper boom; hydraulic basket leveling; continuous rotation; joystick and lockout controls; 180° basket rotator

BASKETS

MH BASKET: Single-person, material handling; top-mounted jib and winch lifts up to 1000#; upper and lower winch control; 400# basket capacity; 24" X 30" fiberglass or aluminum basket

DP BASKET: Double-person, personnel; 600# basket capacity; 24" X 42" fiberglass or aluminum basket

DU BASKET: Dual configuration; double-person, personnel or single-person, material handling; top-mounted jib and winch lifts up to 1000#; 550# basket capacity when not using winch; 400# basket capacity when using winch; 24" X 42" fiberglass or aluminum basket

OPTIONAL

High electrical resistant controls; outriggers; basket liner for fiberglass baskets; fiberglass main and articulating booms; tool circuits; D.C. backup system; 22" basket elevator; aluminum basket; non-insulated version available (DLT2S); 110 v outlet at basket (DLT2S)

REACH DIAGRAM

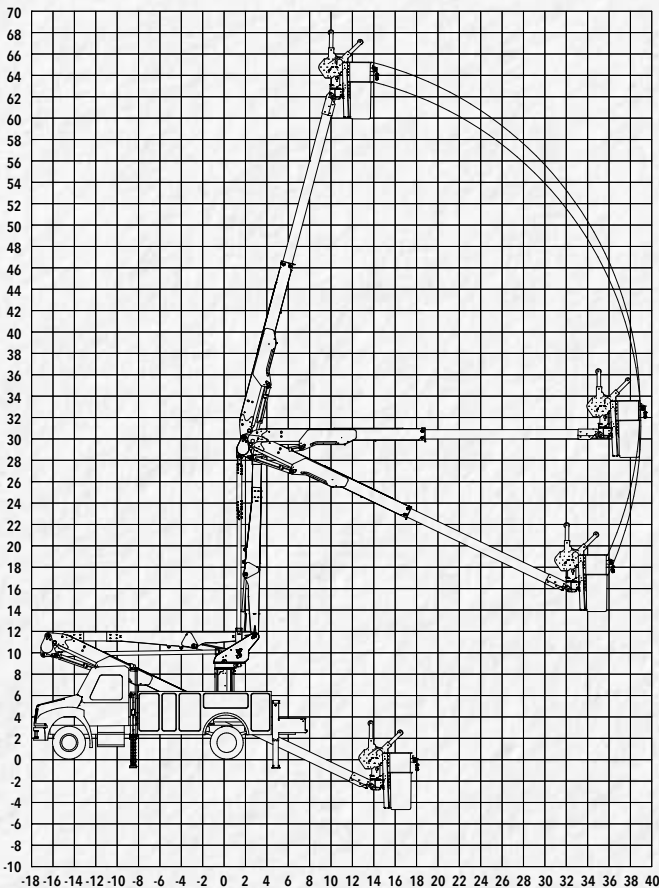

CHASSIS REQUIREMENT, MIN.: 26,000 GVWR
CHASSIS CAB TO AXLE REQUIREMENT, MIN.: 110"



DLT2-60DU PICTURED

INSULATED/NON-INSULATED

DLT2-60: insulated (Category C or D)

DLT2S-60: non-insulated



MH BASKET



DU BASKET



DP BASKET

++
+++



Baskets available in aluminum or fiberglass formats.



BASKET ELEVATOR - The hydraulically activated basket elevator (optional) allows the operator to raise the basket without repositioning the booms or the jib.



DLT2S-60DU

BUILT FOR YOU
Ask about available chassis, body, tailshelf, and basket options.



READ MORE

AMP
www.AMPrents.com
Overhead Utility Equipment Sales and Rentals
AMP Sales & Service, LLC dba AMP Rentals

740 Industrial Blvd, Bedford VA 24523
1+ (540) 586-1021
www.AMPrents.com